

Force Sensor

Datasheet



Properties

This robust and cost-competitive sensor enables force measurement across different applications. Being made of rubber, it tolerates shear forces without damage. It can also be used to measure movements in the range of micrometers. The sensor is equipped with an in-built adaptable electronic that provides standard analog output as well as digital communication IOs. The digital IOs e.g. enable the adjustment of measurement range and alarm criteria – on-the-fly and without any need for mechanical adjustment.

- ◆ Rubberlike sensor tolerating shear forces, shocks, and vibration.
- ◆ Simple installation, perfect for retrofitting.
- ◆ No additional measuring amplifier required (plug and play).
- ◆ Intelligent electronics enabling alarm generation with on-the-fly configuration.
- ◆ Highly customizable in shape, size, and range for applications with unique requirements.
- ◆ High-resolution analog signal output.

Applications

- ◆ Force measurement in **off-road and heavy-duty vehicles**
- ◆ Maximum load detection **elevator, platforms, Automated Guided Vehicle (AGV)**, etc.
- ◆ Force and load measurement at **end effectors in robotics**
- ◆ Presence detection in **industry, logistics, robotics, etc.**
- ◆ **Safety functions** at potential pinch points such as sliding doors, docking points, etc.

Technical Data

- Different information within one row describes orderable options, see chapter ordering code for details.
- All the following information represents our technical standard. Other configurations/specifications are available on request.

Mechanical and Environmental Data

Parameter	Symbol	Value		Unit	Comments
Measurement Range	F_{FS}	100		N	
Weight	m	~ 30		g	Sensor with electronic
Displacement	l_{dis}	< 1.2		mm	@ F_{FS} , in load-direction
Electrical Connection		M8 5-pin	Bare Ends		
Operating Temperature	T_{op}	-55 ... 80		°C	Up to 150°C with separate electronic
Storage Temperature	T_{st}	0 ... 30		°C	
IP Classification		w/o	IP68		

Electrical Data

Parameter	Symbol	Value			Unit	Comments	
Supply Voltage	V_{sup}	12	24	9 ... 30	V	Tolerance ±20%	
Power Consumption	P_{tot}	≤ 1			W		
Analog Outputs	V_{out}	0 ... 10			V	limited by V_{sup}	
	I_{out}		0 ... 20	4 ... 20	mA	Current Output: $R_{sink} \leq \frac{V_{sup} - 2V}{0.02A}$	
Electrical Resolution		12			bit	Resolution of DAC	
Communication		UART				Adapter (PRA) is required	
Digital IOs	Input	V_{IL}	$0 < V_{IL} \leq 2$		V	Logical Low	
		V_{IH}	$10 < V_{IH} \leq 24$		V	Logical High	
	Output		Open Drain				Output characteristics
		V_{OL}	< 2			V	
		I_{OL}	< 250			mA	
		V_{OH}	< 30			V	Pullup dependent
R_{pull}	∞	10		kΩ	Sensor internally to V_{sup}		

Performance Data

Parameter	Symbol	Value	Unit	Comments
Sampling Frequency*	f_s	≤ 1	kHz	Maximum refresh rate of analog output
Resolution		1	%FS	Smallest detectable output change
Repeatability		1.5	%FS	Maximum error when stretched to same value
Accuracy		2	%FS	Including Hysteresis, Noise, Non-Linearity

*Specifications performed at 125 Hz

Force Sensor

Datasheet

Materials

Part	Material
Housing	PLA
Cable	PVC
Bushings	Stainless Steel
Sensor element	PDMS
Others	TPU, nickel-plated brass, CR/NBR, FKM, Aluminum

Please contact us for further information.

Other Materials are available on request.

Electrical Connection

M8 Connector (5M8V & 5M8D)

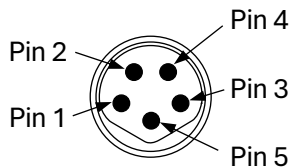

- Pin 1: Supply voltage
- Pin 2: DIO 0
- Pin 3: Ground
- Pin 4: DIO 1
- Pin 5: Analog Out

IEC 61076-2-104 B-coded M8

Bear Ends (5BED)

- White: Supply Voltage
- Brown: DIO 0
- Green: Ground
- Yellow: DIO 1
- Gray: Analog Out

Other electrical connections are available on request!

Mechanical Dimensions

M8 5-pin connector in housing (5M8V)

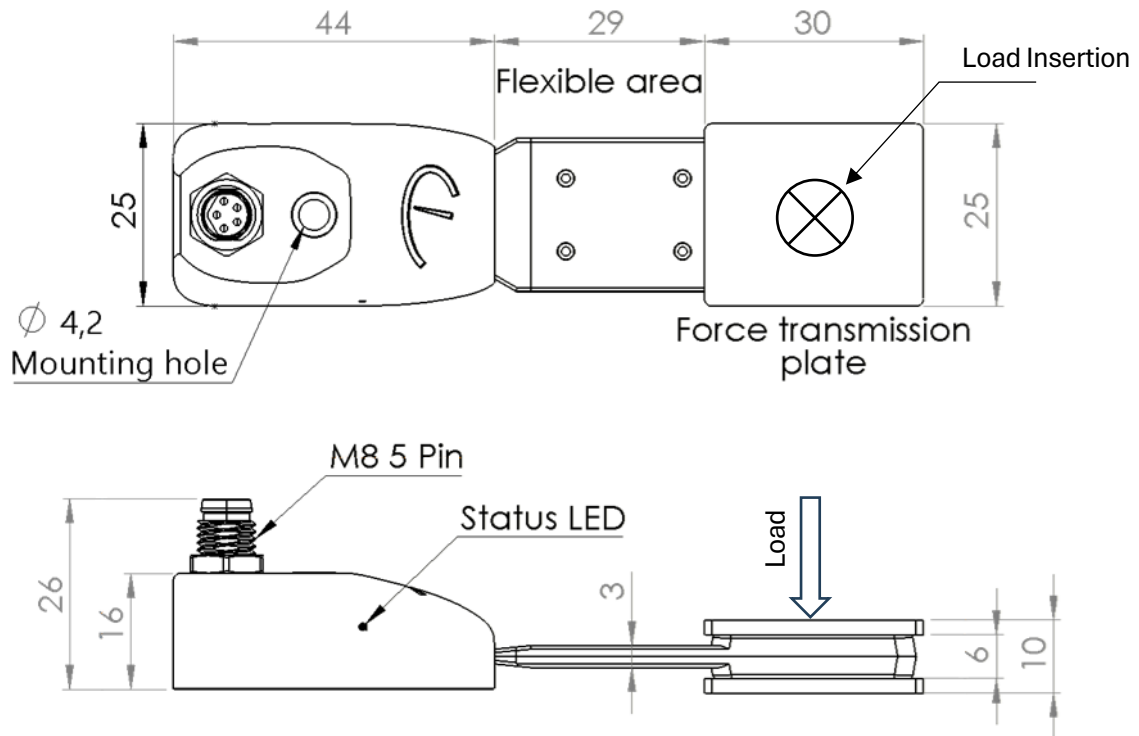

Figure 1: Drawing of Sensor 5M8V - M8 Male plug in housing

Cabled versions (5BED & 5M8D)

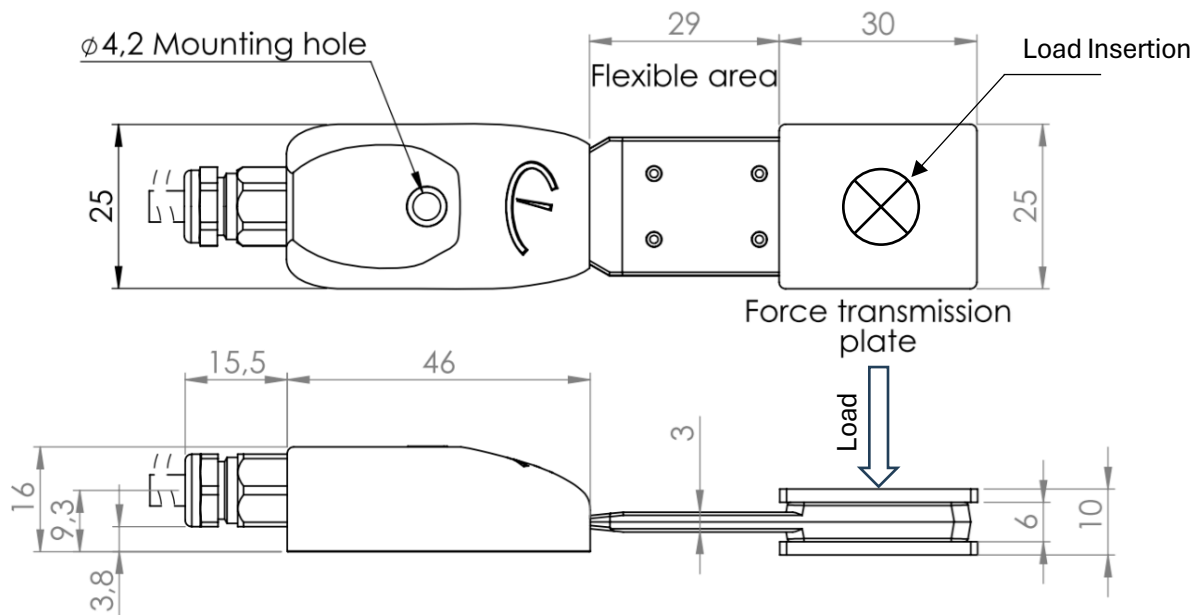

Figure 2: Drawing of Sensor 5M8C & 5BEC - Cabled version

Other lengths or mounting conditions are available on request!

Delfa Systems GmbH ♦ Im Altseiterstal 7 ♦ 66538 Neunkirchen ♦ info@delfasys.de ♦ +49 (0) 68 21-91 37 100

Subject to change without notice. All information describes our products in general terms. It does not constitute a guarantee of quality or liability in accordance with §443 BGB. The information does not constitute any liability. Specifications are subject to change without prior notice.

Force Sensor

Datasheet



Order Code

		DLO	-	S1M4	-	100	-	5M8V	-	24	-	2H	-	I0	-	00	-	XXXX	
Type																			
	DLO	Delfa Load System																	
Housing Type																			
	S1M4	PA12, M4 with Stainless steel bushings																	
Range																			
	100	Measurement Range 0...100 N																	
Electrical Connection																			
	5M8V	M8 Male plug in housing IEC 61076-2-104 b-coded																	
	5M8D	2 m cable with male M8 plug IEC 61076-2-104 b-coded																	
	5BED	2 m cable with bare ends																	
Supply Voltage ^{*1)}																			
	12	12 VDC																	
	24	24 VDC																	
	9X	9 - 30 VDC																	
Sampling Rate																			
	1X	10 Hz																	
	1C	100 Hz																	
	2H	250 Hz																	
	5H	500 Hz																	
	1K	1.000 Hz																	
Analog Output																			
	00	w/o																	
	U1	0 - 10 V																	
	I0	0 - 20 mA																	
	I4	4 - 20 mA																	
Digital Ports ^{*2)}																			
	00	w/o																	
	2I	Two digital Inputs to teach																	
	IO	one Input, one Output																	
	2O	Two digital Outputs																	
Optional Features (separate table)																			

Standard Product

Other options (sensor range, supply & output voltage, housing, communication, cable lengths, ...) available on request.

*1) Maximum analog output limited by supply voltage

*2) Digital ports are preconfigured, programming adapter PA-GPIO is recommended to adjust limits via software

Optional Features

Multiple selection possible, add corresponding suffix to end of order code without separator.

Leave blank if no options are desired.

Order code table	
PU	Digital Output: 10 kΩ Pull-up (Only available when Digital Output(s) is/are chosen.)
IP	IP68 protection(*), only available for cabled versions (e.g. 5M8D, 5BED)

(*): Development in progress, please contact us for further information

Customer-specific sensor systems are assigned a factory order code.

Digital IO's and Communication

- All digital outputs are open drain low-switching (NPN) type, external pull-up is required. (An internal 10 kΩ Pull-up is available as an optional feature)
- By default, the digital outputs are high when the assigned limit is exceeded.
- By default, digital inputs react on a digital high (positive logic). Always tie unused inputs to Ground.
- Other switching options (e.g. output change to digital low when exceeding a limit; pulse instead of edge; ...) are available on request.
- All limit values can be set by software with the programming adapter (PRA-GPIO) or with corresponding digital inputs.
- Outputs can be used to switch e.g. a relay, a valve, or an alarm system.

Functionality of the digital IOs according to the ordered configuration

	2I	IO	2O
DIO 0	Set min limit	Limit 1 (Output)	Limit 1
DIO 1	Set max limit	Set Limit 1 (Input)	Limit 2

Option “2I”: Two digital Inputs to teach the analog output

This option enables defining the positions where the minimum and maximum analog signal should be output using the digital inputs. When an input is activated, the current position is latched as the value for the according analog signal limit. This enables the user to focus the analog output on a specific range of interest. The limits can also be adjusted using the programming adapter PRA-GPIO.

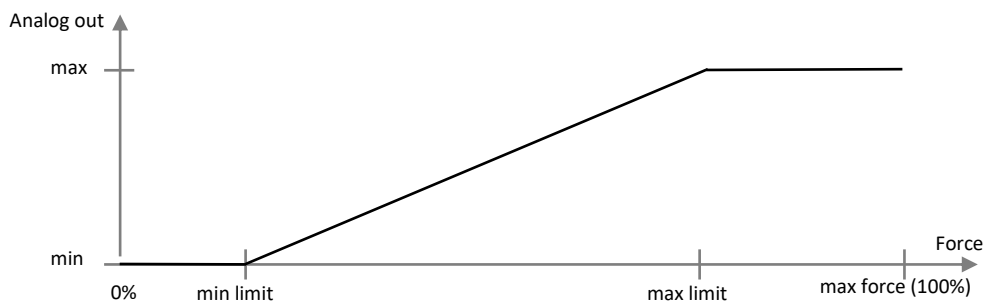

Figure 1: Analog output signal with taught limits.

Option “IO”: 1 digital input to teach a limit and 1 digital output signal

This option is used for generating an alarm or control signal when a maximum displacement value, configured in software, is exceeded. It can be used to mimic a limit switch generating a digital signal output. The limit can be adjusted using the digital Input or the programming adapter PRA-GPIO.



Figure 2: Digital output signal vs. force.

Option “2O”: 2 digital output signals

This option is used for generating two alarm or control signals when a minimum or maximum displacement value, configured in software, is exceeded. It can be used to mimic two limit switches generating a digital signal output. The limit can be adjusted using the programming adapter PRA-GPIO.

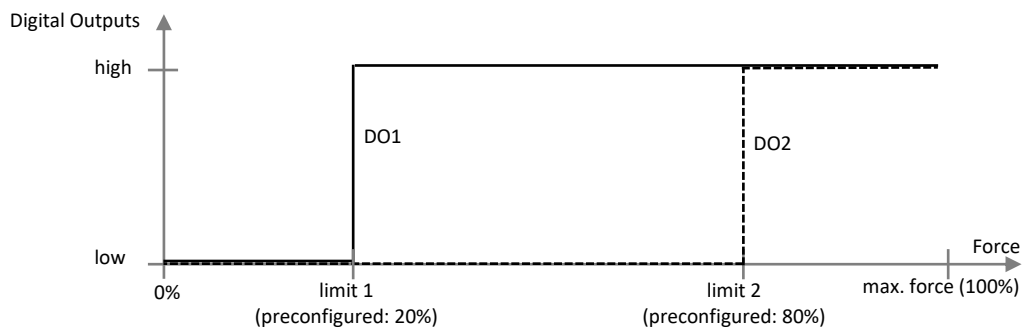

Figure 3: Digital output signals vs. force.

Analog Output

The limits for the analog output signal (i.e. the sensor position for minimum / maximum output signal) can always be changed using the programming adapter PRA-GPIO.

Please take care that the maximum voltage of the voltage output signal is limited to the supply voltage if this is less than 10 V.

This also applies to current output devices. Always select the burden resistor R_{sink} in that way, that with full output current more than 1 V between the supply and the voltage of the output pin is guaranteed (supply higher than output). This can be done by using this formula:

$$R_{sink} \leq \frac{V_{sup} - 2 V}{0.02 A}$$

Optional Features

Temperature Compensation

To improve the temperature stability, an optional temperature compensation can be ordered. If this is used, due to self-heating of the system, stability will be reached after a run-in time of approximately 15 minutes.

The performance of the compensation can be influenced by temperature differences between the electronic housing and the sensitive element e.g. due to radiant heat. For best performance, the temperature of all parts should be as close as possible.

Pullup for Digital Outputs

Additional Pullup-Resistors with a resistance of 10 kOhm between the output and the supply voltage are added.

Protection Class IP68

Extended protection of the sensor against water reaching IP68 classification. This is only available with cabled connections.

Accessories

- ◆ Programming Adapter **PRA-GPIO**
- ◆ Sensor Cable **SCA-...**
- ◆ Communication adapter for RS422/485, RS232 **PRA-COM...**

Distributor



Delfa Systems GmbH ♦ Im Altseiterstal 7 ♦ 66538 Neunkirchen ♦ info@delfasys.de ♦ +49 (0) 68 21–91 37 100

Subject to change without notice. All information describes our products in general terms. It does not constitute a guarantee of quality or liability in accordance with §443 BGB. The information does not constitute any liability. Specifications are subject to change without prior notice.